

ELECTRICAL VEHICLE POWER LINE COMMUNICATION

KOMUNIKASI SALURAN LISTRIK KENDARAAN LISTRIK

Alexander Tristan Darui¹, Don Bosko Satria Yogsakti², Raihany Afifa Augusta³, Reza Gustyan Sukmara⁴

^{1,2,3,4}Prodi S1 Teknik Elektro Kelas Internasional, Fakultas Teknik Elektro, Universitas Telkom

¹alextristan@student.telkomuniversity.ac.id, ²donbosko@student.telkomuniversity.ac.id,

³Raihany@student.telkomuniversity.ac.id, ⁴rezagustyansukmara@student.telkomuniversity.ac.id

Abstract

Nowadays, electric vehicle is starting to be a regular thing in a daily life, especially in advanced countries, while Indonesia is currently adopting that concepts. In an electric vehicle, there is a Controlled Area Network (CAN) which functions as the central area for all the data distribution through out the vehicle, including sensors, part conditions, and others. Inseparable activity from electric vehicles is charging, since it is one of the most crucial factors to runs properly. Having a communication mechanism between the vehicle with the charging station would give benefits, for both the user also the vehicle, making it possible to have a direct diagnostic of the vehicle state while regularly charging it. That is the main reason for a developmet in Electric Vehicle Power Line Communication (EVPLC). The goal is to assure that it is possible to have a data transfer activity with bidirectional communication mechanism through the running AC current that charges the battery of the vehicle. While grasping that concept, the researchers created an EVPLC module through a simulated Electrical Vehicle Charging Station (EVCS) and Electrical Vehicle Controlled Area Network (EVCAN) simulation to prove the concept to be implemneted onto a real EVCS and electric vehicle.

Keywords : CAN, Bidirectional, EVCS, EVCAN, AC

Abstrak

Jaman sekarang, kendaraan listrik mulai menjadi hal yang umum dalam kehidupan sehari-hari, terutama di negara-negara maju, sementara Indonesia sedang mengadopsi konsep tersebut. Dalam kendaraan listrik, terdapat Jaringan Area Terkendali (CAN) yang berfungsi sebagai pusat distribusi data di seluruh kendaraan, termasuk sensor, kondisi komponen, dan lainnya. Aktivitas yang tak terpisahkan dari kendaraan listrik adalah pengisian daya, karena ini merupakan salah satu faktor penting agar kendaraan berfungsi dengan baik. Memiliki mekanisme komunikasi antara kendaraan dengan stasiun pengisian daya akan memberikan manfaat, baik bagi pengguna maupun kendaraan itu sendiri, memungkinkan diagnosis langsung tentang kondisi kendaraan saat pengisian daya secara berkala. Itulah alasan utama pengembangan Komunikasi Jalur Daya Kendaraan Listrik (EVPLC). Tujuannya adalah memastikan bahwa ada kemungkinan aktivitas transfer data dengan mekanisme komunikasi dua arah melalui arus AC yang digunakan untuk mengisi baterai kendaraan. Dengan memahami konsep tersebut, para peneliti menciptakan modul EVPLC melalui simulasi Stasiun Pengisian Kendaraan Listrik (EVCS) dan simulasi Jaringan Area Terkendali Kendaraan Listrik (EVCAN) untuk membuktikan konsep ini dapat diimplementasikan pada EVCS dan kendaraan listrik yang nyata.

Kata Kunci: CAN, Dua Arah, EVCS, EVCAN, AC

1. Introduction

1.1 Backgrounds

Over the years, electric vehicles have become a common part of daily human lives, especially in advanced countries. This event is driven by the efficiency and technological advancement provided by electric vehicles and the growing awareness towards a healthier way of living for the environment. Here in Indonesia, fossil-fueled vehicles still become society's favorite since most electric vehicles are still out of reach for most Indonesian citizens because of the soaring prices, and the low will to try new technological advancements since society already can rely on fossil-fueled vehicles for decades. Yet, there is growth in Indonesia, in both government and society, in the transition process from fossil-fueled vehicles to electric vehicles. Some societies are already willing to change their vehicle to electric vehicles, both cars and scooters, and the government creates regulations that support the usage of electric vehicles like lower vehicle taxes, free from even-odd regulations, and even infrastructure that supports the usage of electric vehicles such as the rapid growth of charging stations for electric vehicles [1]. Those previous actions created a thriving momentum for using electric vehicles in Indonesia.

In electric vehicles, there is an applied technology called the CAN (Central Area Network) Bus. CAN-Bus is one type of automotive bus. An automotive bus is a communication network that interconnects underlying automotive devices or automotive instruments in the in-vehicle network. CAN bus was originally designed by Bosch in 1989 for automotive monitoring and controls and was used in communications between the measurement and execution components of a car [2]. It can be summarized that CAN-Bus is a protocol that has a direct relation with the components inside the vehicle, which means that through CAN-Bus, it is possible to observe the current condition of the components inside the vehicle. Based on the research document titled “*Pengembangan Sistem Kontrol Mobil Listrik Berbasis CAN-BUS*” by the National Technology Institute, there are several components in electric vehicles that can be integrated with CAN-BUS [3]. These are vehicle control systems, energy storage systems, motor and power inverters, charging station infrastructure, vehicle support systems, and transmission. In this research, the researchers are focused on the energy storage system in electrical vehicles. Since the wiring mechanism is already available through the implementation of CAN-Bus, the technology can become a part of the *Smart Grid* implementation in the electric vehicle industry through the presence of a *gateway*. This can be implemented through the presence of PLC (Power Line Communication). Power Line Communication (PLC) presents some natural advantages that make it appropriate for this kind of application, such as the advantage of using the already deployed electrical grid as the communication medium [4].

Unfortunately, EV-PLC technology is still uncommonly used in the market nowadays, even in advanced countries. By not using EV-PLC technology, the user needs to go to the workshop only to analyze the complete condition of the EV since not every electric vehicle is built with an embedded network that can analyze the state of the vehicle, especially in electric motorbikes that recently became commonly uses by Indonesian drivers. Different kinds of electric vehicles can use different kinds of current and voltage levels which will affect the battery health in the long run. Combining both technologies can bring abundant benefits to both the user of the electric vehicle and the industry because it would enable them to analyze every component that is connected and reprogram it to the user’s satisfaction. Following further developments, it can self-diagnose the components in the electric vehicle. In the previous year, a group of students from Telkom University works on research with the title of “*Perancangan Stasiun Pengisian Kendaraan Listrik Umum di Lingkungan Telkom University*” [5]. From that research, the students created a charging station in which the communication system through the power line can be detected with the applied electric vehicle. Yet communication still works on the basic impedance principle. This research aims to form an electronic device that can be implemented in several kinds of charging stations and works as a gateway technology between the electronic vehicle and the charging station. Of course, considering the IEC (International Electrotechnical Commission) standardization that is mainly used for electrical vehicles in Indonesia.

In recent times, there have been a handful of companies that have created this kind of gateway technology. Those companies are Continental Engineering Services (CES) which is based in Frankfurt, Germany; Renault from France; Xingtera and Star Charge from China. As previously mentioned, the goal of this research is to create a working EV-PLC (Electrical Vehicle Power Line Communication) that can be a communication interface between the applied electric vehicle and the charging station. The purpose of this activity is to initiate the research and manufacturing initiative of EV-PLC technology in Indonesia considering the growth of interest in electrical vehicles in Indonesia.

1.2 Requirements to be Fulfilled

The needs that must be met based on the existing background are as follows:

1. The instrument can convert the given PLC signals into recognizable data for the EVCAN Simulator.
2. The instrument can communicate data bidirectionally between Electric Vehicle Charging Stations (EVCS) with an EVCAN Simulator.

1.3 Purpose

This research proposes the development of an Electrical Vehicle Power Line Communication (EVPLC) system in Indonesia. The system aims to establish reliable communication between the Electric Vehicle Charging Stations (EVCS) and the CAN Bus system in electric vehicles. It simplifies wiring, enhances safety, and allows for real-time analysis and diagnosis of vehicle components. The document highlights the limited availability of domestically manufactured EVPLC systems in Indonesia and the benefits of combining EVPLC with CAN Bus technology. The proposed solution prioritizes functionality over aesthetics and focuses on improving data transmission accuracy, communication capabilities, casing quality, and programming language. The objectives include developing an efficient and accurate instrument for signal conversion, designing the instrument to operate with AC current, equipping it with diagnostic capabilities, manufacturing it domestically, and ensuring scalability. The document emphasizes the alignment of the proposed EVPLC system with Indonesia's clean energy goals and global efforts to achieve Net Zero Emissions.

2. Supporting Information & System Design

2.1 Supporting Information

Before CAN was introduced, each electronic device was connected to other devices using many wires to enable communication. But when the functions in the automobile system increased, it was difficult to maintain because of the tedious wiring system. With the help of the CAN bus system, which allows ECUs to communicate with each other without much complexity by just connecting each ECU to the common serial bus [6]. The CAN bus protocol was initially designed as an alternative to field-bus technology in automobiles that would improve functionality [7]. The first car to ever feature this technology was the BMW 850 Coupe that entered the market in 1986. It was able to reduce in-vehicle wiring by 2km, which consequently significantly reduced its weight by over 50kg. Not to mention, the vehicle systems and sensors were able to communicate with each other at speeds up to 25kbps - 1Mbps [7].

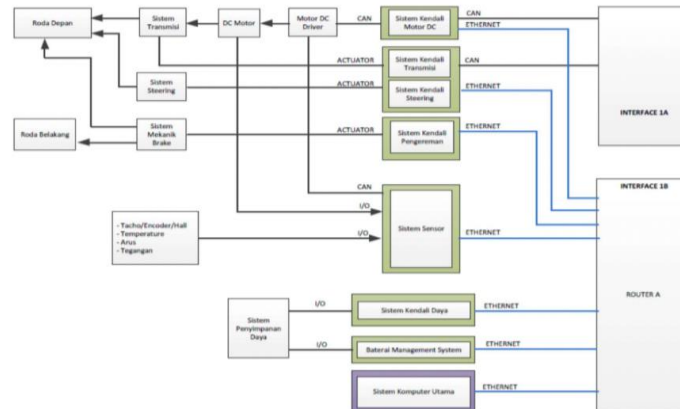

Figure 1. Electrical Vehicle Network Block Diagram for CAN

In figure 1 it shows there are several components in electric vehicles that can be integrated with CAN-BUS. These are vehicle control systems, energy storage systems, motor and power inverters, charging station infrastructure, vehicle support systems, and transmission. In this research, the researchers are focused on the energy storage system, who's the data will be received by EVPLC. The adoption of Electric Vehicle-Power Line Communication (EVPLC) technology in Indonesia holds significant promise, serving as a vital bridge between the established CAN-Bus technology in electric vehicles and the charging infrastructure. This advancement not only facilitates seamless communication between EVs and charging stations but also opens opportunities for real-time analysis, reprogramming, and self-diagnosis of vehicle components, enhancing the user experience and reducing maintenance costs.

2.2 Product Requirements & Specifications

The requirements and specifications that needs to be fulfilled during this research are summarize into the table below.

Table 1. Research Requirements & Spesification

No	Requirements	Specifications
1	The instrument can convert the given PLC signals into recognizable data for the EVCAN Simulator.	Specification 1: The given PLC signals can be recognized with CAN Bus Protocol as an embodiment of the EVCAN Simulator system.
2	The instrument can communicate data bidirectionally between Electric Vehicle Charging Stations (EVCS) with an EVCAN Simulator.	Specification 2: The instrument is capable of transferring and receiving data for the EVCS and EVCAN Simulator.

2.3 Solution Concept

Overall Function

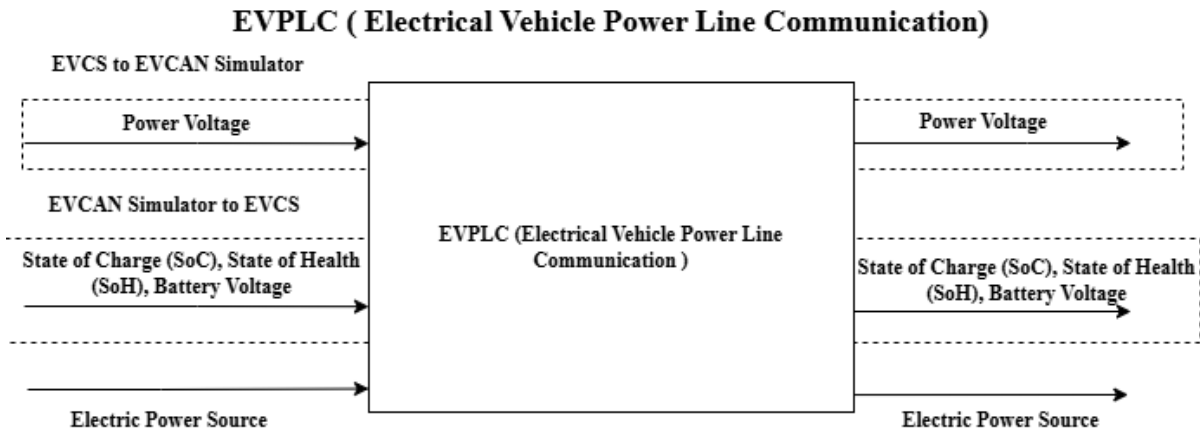

Figure 2. Overall Function EVPLC (Electrical Vehicle Power Line Communication)

Based on the function block diagram above (Figure 2), Overall Function of Electric Vehicle Powerline Communication, the Communication System in the system can be bidirectional therefore it has 2 inputs, the first input is Data from EVCS in the form of Power Voltage Data, and will produce output Power Voltage data that has been demodulated and will be displayed on the Control Pilot EV or HMI of EVCAN Simulator, then the second input is from the EV in the form of State of Charge (SoC), State of Health (SoH) and Battery Voltage Data, and will produce data output State of Charge (SoC), State of Health (SoH) and Battery Voltage Data which will be displayed on the HMI from EVCS.

2.4 Chosen Components & System Design

Based on the previous information regarding the research requirements, specifications, and solution concepts, here is the list of the selected components to create a working EVPLC module. The list is shown in the table below.

Table 2. List of Selected Components

Selected Components	
Microcontroller	Arduino Nano
Case Material	Acrylic
LCD	I2C 20x4
PLC Module	KQ-330
CAN	MCP2515
Voltage Sensor	ZMPT101B
Power Supply	Power Bank
HMI (Human Machine Interface)	Nextion (NX4024K032_011)

For the system design, it would be a working PCB which can perform data communication with both CAN and AC current mechanism. The PCB would be placed inside of the EVPLC module casing as shown in the figure below.

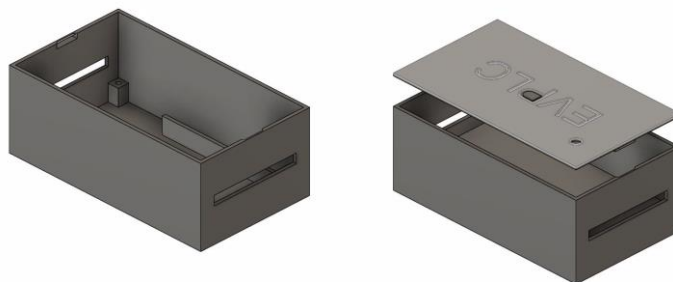

Figure 3. EVPLC Module Casing Design

3. Contents

According to solution concept that is stated in part 2, the EVPLC module will consist of 3 main parts, which are a communication module (KQ330), a microcontroller for the main program (Arduino nano), and a CAN-BUS which will be working as a gateway to the existing CAN-BUS (MCP2515). The reason for that action is to create a portable module that can be easily plugged into an existing CAN-BUS that we desired without embedding a new circuit to connect the existing CAN-BUS to the microcontroller which connects to the communication module for AC communication which in this case we use KQ330. The CAN-BUS that we chose for this project is MCP2515. For the system implementation testing, we use an LCD Screen, a DHT 11, 2 MCP2515, 3 microcontrollers, and 2 KQ330. For the system implementation testing, we collect the data from DHT 11 and send it to another microcontroller which is connected to an MCP2515 that stands as the CAN-BUS for the final product. After the data has been received, the data are sent to the other CAN-BUS that is also connected to its microcontroller which in this case stands as the existing CAN-BUS. Finally, the received data will be presented on the LCD screen. This projects the whole system and later on in the real testing, we will be sending data from the sensor in the EVCS which will received by the existing CAN-BUS The system implementation circuit is as follows

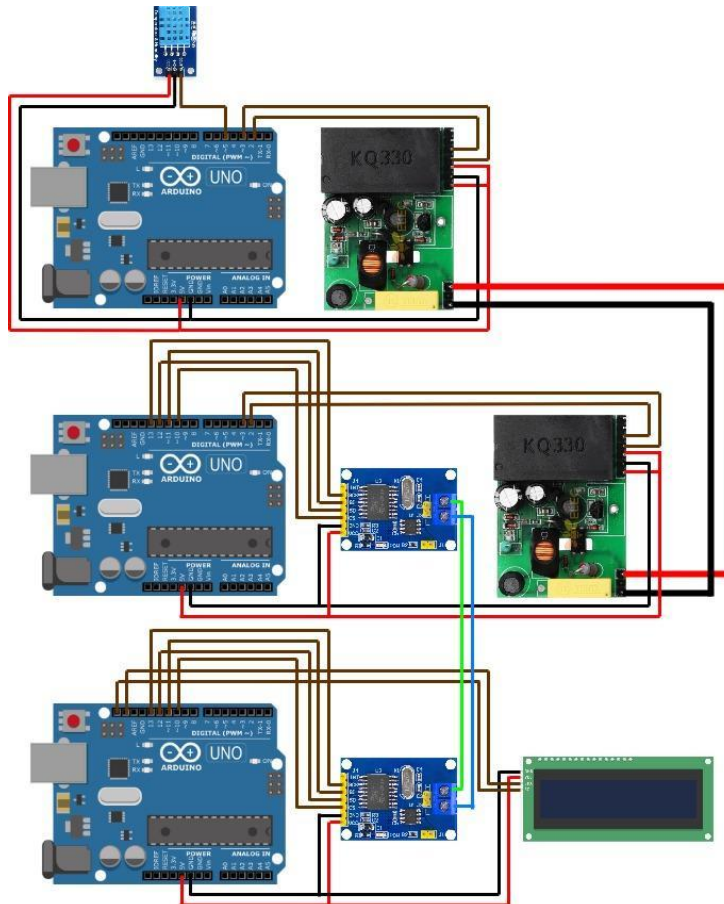

Figure 4. Wiring Diagram of Full System of EVPLC Module Testing

The result of this is successful. The data collected from DHT 11 is shown on the LCD Screen. The documentation is as follows.



Figure 5. LCD Screen for Full System EVPLC Module Testing

After the successful tryouts, the researchers finalize the circuit design for the integrated EV-PLC module. This module would consist of 3 main components, which are Arduino Nano, MCP 2515 (CAN Module), and KQ330 (AC Communication Module). Based on the previous tryouts, the finalized version of the EV-PLC module is as follows.

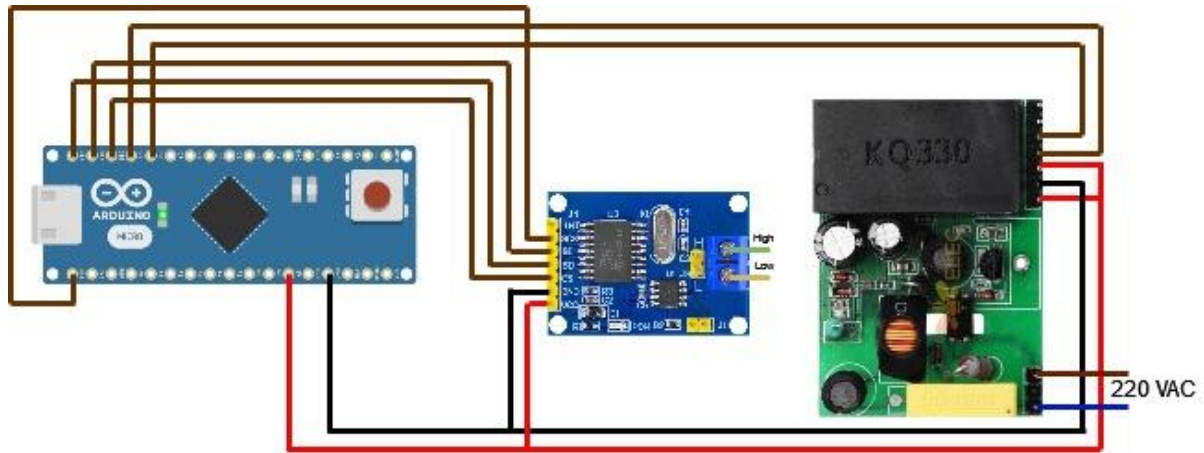

Figure 6. Wiring Diagram of EVPLC Module

Since the researchers already have the final circuit for the module, the next step for the module finalization process is to create the PCB design from the previous circuitry. The PCB design is created through Sprint Layout V6. The PCB design for the EV-PLC module is as follows.

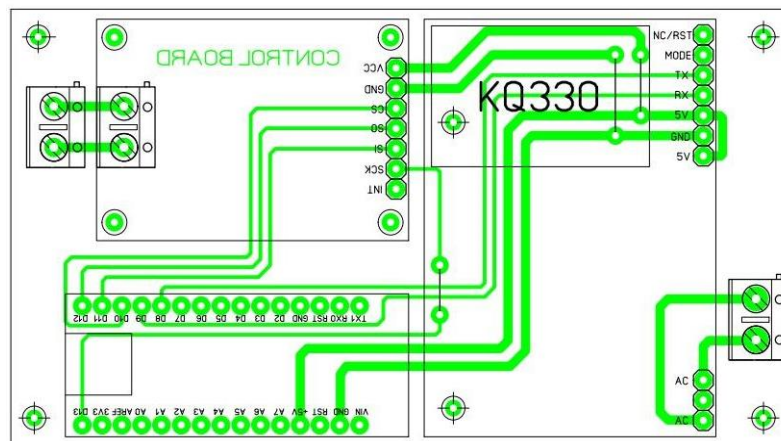

Figure 7. PCB Design for EVPLC Module

Other than the EVPLC Module, the researchers also need to create an EVCS Simulation for assuring that the EVPLC module can perform while also charging the battery that is connected in the EVCAN Simulation system. Please note that this is an EVCS Simulation, not a real EVCS. This simulation would not be capable of charging a real electric vehicle or have a complete function of a real functioning EVCS. This simulation is created to prove that the created EV-PLC system is working properly and fulfills the objectives of the product if it is being implemented in a real EVCS with certain modification to adjust with the final EV-PLC product implementation. The EVCS will gain data through the integrated sensor and send the result to the EV-CAN Simulator, both through the EV-PLC module.

To fulfill the research requirements, the EVCS simulation should have the PCB which covers all of the requirements. The microcontroller that is used in the EVCS simulation is Arduino Nano. To fulfill the goal of data gathering, the researchers embedded a voltage sensor, ZMPT101b. This sensor would sense the value of voltage that is powering the whole EVCS simulation system. Later on, the result of this sensor would be displayed on the EVCS simulation and send the value to the EV-CAN Simulation to represent the bidirectional communication process. For the PCB to be able to communicate with the EV-PLC system, the researchers put a CAN module, MCP2515, that later on will connect with the CAN in the EV-PLC system. There would be ports for jumper wires to connect directly with pin D5 and D7 which would be responsible for running the

HMI that's embedded with the EVCS simulation, Nextion (NX4024K032_011). The wiring of the PCB board is as follows.

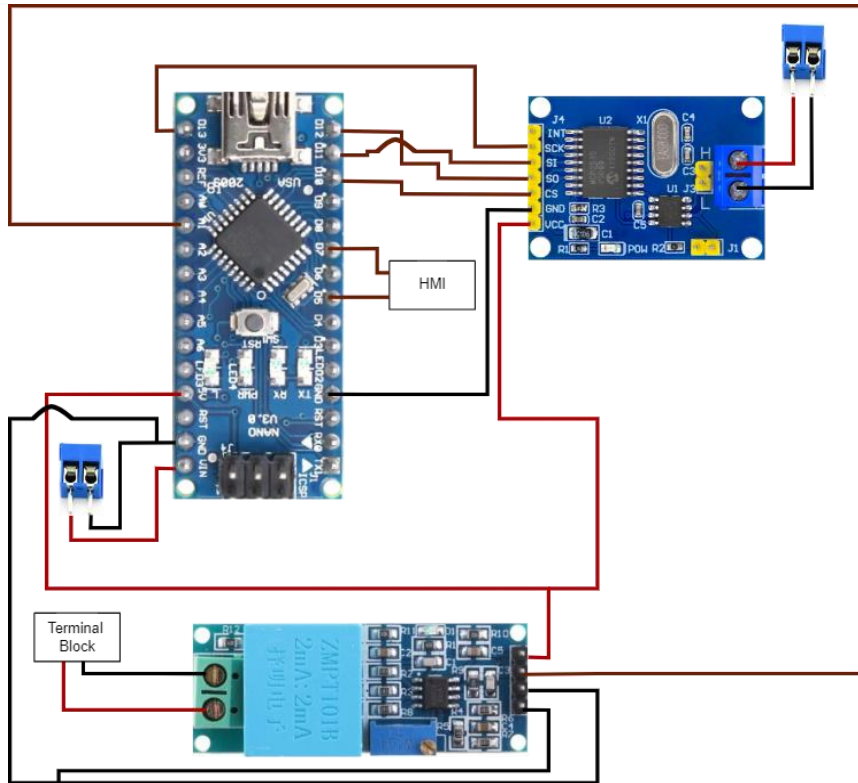

Figure 8. Wiring Diagram for EVCS Simulation PCB

Since the researchers has the wiring for the PCB that is going to be embedded into the EVCS Simulation system, the next part is to create the real PCB board and assembly it along with the required circuitry that also create the complete and working EVCS Simulation that can perform as it requires. After being complete with the EVCS simulation, the researchers test the EVPLC module with both EVCS Simulation and EVCAN Simulation to test the success of the EVPLC module. From the test, it gives great result and fulfills all of the module requirements. This also proves that integrating the EVPLC module into a real EVCS and electric vehicle is possibly and beneficial. The documentation of the final test are as follows.

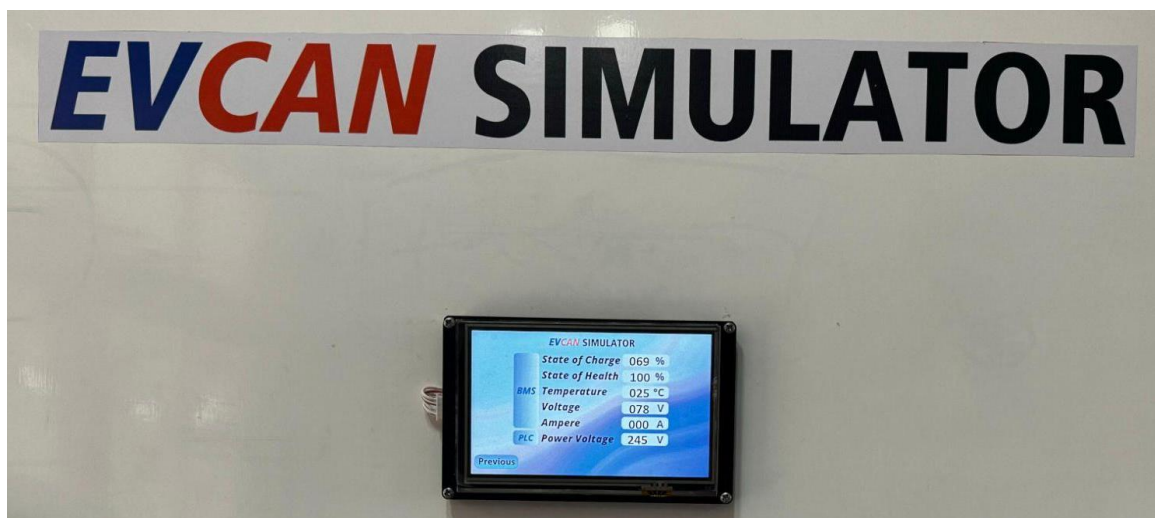

Figure 9. HMI of EVCAN Simulator



Figure 10 HMI of EVCS Simulation

4. Summary

EVPLC (Electrical Vehicle Power Line Communication) Module is created to fulfill the needs of new technology development that supports the operational of an electrical vehicle. As an electrical vehicle, it would not be separated from a charging process since it becomes one of the most crucial things for an electrical vehicle to runs. From that information, a relation between an electric vehicle with the charging station is inevitable. Also knowing that electrical vehicle would have CAN (Controlled Area Network) mechanism for integrating all of the sensors and data that runs inside an electrical vehicle. Combining these two conditions, become the foundations for the EVPLC module research. Through testing with EVCAN Simulator and EVCS Simulator, EVPLC proves that it is possible to implement AC communication mechanism with electrical vehicle. With further developments, the EVPLC module can be implemented with a real EVCS and electrical vehicle. This would be beneficial since this communication opens up several gates of opportunities in developing a better system for electrical vehicles especially in monitoring the real time conditions.

Bibliography:

- [1] Biro Komunikasi dan Informasi Publik, "Pemerintah Terus Dorong Penggunaan Mobil Listrik," Kementrian Perhubungan Republik Indonesia.
- [2] J. N. Luo, C. M. Wu, and M. H. Yang, "A can-bus lightweight authentication scheme," *Sensors*, vol. 21, no. 21, Nov. 2021, doi: 10.3390/s21217069.
- [3] T. K. S. T. M.T, Dr. Waluyo MT., and S. S. T. M.T., "Pengembangan Sistem Kontrol Mobil Listrik Berbasis CAN-Bus," *IEEE*, 2016.
- [4] G. López *et al.*, "The role of power line communications in the smart grid revisited: Applications, challenges, and research initiatives," *IEEE Access*, vol. 7, pp. 117346–117368, 2019, doi: 10.1109/ACCESS.2019.2928391.
- [5] P. Stasiun and P. Kendaraan, "BUKU TUGAS AKHIR CAPSTONE DESIGN."
- [6] Akhila Nagaruru, "Understanding Controlled Area Network (CAN) for Automobile Industry needs," PATHPARTNER. Accessed: Oct. 20, 2023. [Online]. Available: <https://www.pathpartnertech.com/understanding-controlled-area-network-can-for-automobile-industry-needs/>
- [7] "CANBus: The Central Networking System Of Vehicles," premio. Accessed: Oct. 20, 2023. [Online]. Available: <https://premioinc.com/blogs/blog/can-bus-the-central-networking-system-of-vehicles>